

## Fill Ups of Miscellaneous (Sets, Relations, Statistics & Mathematical Reasoning)

**Q. 1.** A variable takes value  $x$  with frequency  ${}^{n+x-1}C_x$ ,  $x = 0, 1, 2, \dots, n$ . The mode of the variable is..... (1982 - 2 Marks)

**Ans. n**

**Sol.** Frequency for variable  $x$  is  ${}^{n+x-1}C_x$  where  $x = 0, 1, 2, \dots, n$ .

Mode is the variable for which freq. is max.

Now,  ${}^nC_r$  is max for  $r = n/2$ , if  $n$  is even

$$r = \frac{n+1}{2} \text{ If } n \text{ is odd.}$$

If  $n + x - 1$  is even then for max value of  ${}^{n+x-1}C_x$ ,

$$x = \frac{n+x-1}{2} \Rightarrow x = n-1, \therefore \text{freq. } {}^{2n-2}C_{n-1}$$

If  $n + x - 1$  is odd then for max value of  ${}^{n+x-1}C_x$

$$x = \frac{n+x-1+1}{2} \Rightarrow x = n, \therefore \text{freq. } {}^{2n-1}C_n$$

$$\text{But we know } {}^{2n-1}C_n = \frac{2n-1}{n} {}^{2n-2}C_{n-1}$$

$$\text{i.e., } {}^{2n-1}C_n > {}^{2n-2}C_{n-1}$$

$\therefore$  Mode should be  $n$ .

## True False of Miscellaneous (Sets, Relations, Statistics & Mathematical Reasoning)

**Q.1.** For real numbers  $x$  and  $y$ , we write  $x * y$  if  $x - y + \sqrt{2}$  is an irrational number. Then, the relation  $*$  is an equivalence relation. (1981 - 2 Marks)

**Ans. F**

**Sol.** Given that,  $x * y = x - y + \sqrt{2}$

Consider  $x = 2\sqrt{2}$ ,  $y = \sqrt{2}$

Then  $x * y = 2\sqrt{2} - \sqrt{2} + \sqrt{2} = 3\sqrt{2}$  (irrational)

And  $y * x = \sqrt{2} - 2\sqrt{2} + \sqrt{2} = 0$  (rational)

$\therefore x * y \neq y * x$

Hence  $*$  is not symm.  $\Rightarrow *$  is not an equivalence relation

## Subjective questions of Miscellaneous (Sets, Relations, Statistics & Mathematical Reasoning)

**Q.1.** An investigator interviewed 100 students to determine their preferences for the three drinks : milk (M), coffee (C) and tea (T). He reported the following : 10 students had all the three drinks M, C and T; 20 had M and C; 30 had C and T; 25 had M and T; 12 had M only; 5 had C only; and 8 had T only.

Using a Venn diagram find how many did not take any of the three drinks. (1978)

**Ans. Sol.** We have

$n(U) = 100$ , where U stands for universal set

$n(M \cap C \cap T) = 10$ ;  $n(M \cap C) = 20$ ;

$n(C \cap T) = 30$ ;  $n(M \cap T) = 25$ ;

$n(M \text{ only}) = 12$ ;  $n(\text{only } C) = 5$ ;

$n(\text{only } T) = 8$

Filling all the entries we obtain the Venn diagram as shown :

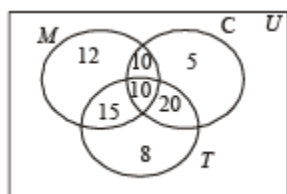

$$\therefore n(M \cap C \cup T) = 12 + 10 + 5 + 15 + 10 + 20 + 8 = 80$$

$$\therefore n(M \cup C \cup T)' = 100 - 80 = 20$$

**Q.2. (a)** Construct a triangle with base 9 cm and altitude 4 cm, the ratio of the other two sides being 2 : 1.

**(b)** Construct a triangle in which the sum of the three sides is 15 cm with base angles  $60^\circ$  and  $45^\circ$ . Justify your steps.

(1979)

**Ans. Sol.** (a) To construct a  $\Delta$  with base = 9 cm, altitude = 4 cm and ratio of the other



two sides as 2 : 1.

**Steps of Construction:** 1. Draw  $BC = 9$  cm

2. Divide  $BC$  internally at  $P$  and externally at  $Q$  in the ratio 2: 1.

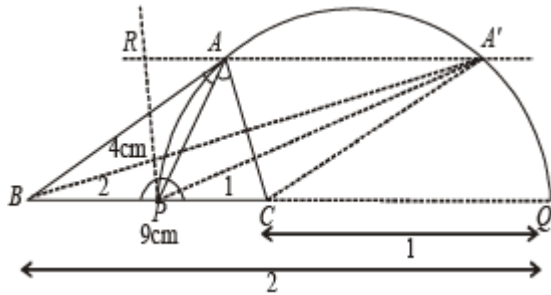

3. Draw a semicircle on  $PQ$ .

4. Draw a line  $\parallel BQ$  at a distance of 4 cm from intersecting semicircle at  $A$  and  $A'$ .

5.  $ABC$  and  $A'BC$  are the required  $\Delta$ 's.

(b) To construct a  $\Delta$  with perimeter = 15 cm, base angles  $60^\circ$  and  $45^\circ$ .

**Steps of Construction:**

1. Draw  $PQ = 15$  cm

2. At  $P$  draw  $\angle RPQ = 60^\circ$  and  $\angle XPQ = \frac{60^\circ}{2} = 30^\circ$  ...

And at  $Q$  draw  $\angle SQP = 45^\circ$  and  $\angle YQP = \frac{45^\circ}{2} = 22\frac{1}{2}^\circ$

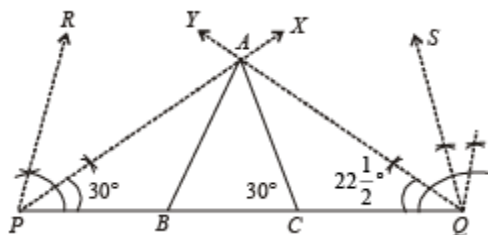

3.  $PX$  and  $QY$  meet each other at  $A$ .

4. Through  $A$  draw  $AB \parallel PR$  and  $AC \parallel QS$ .

5. ABC is the required  $\Delta$ .

**Justification:** Q AB  $\parallel$  PR and PA transversal

$$\therefore \angle PAB = \angle RPA = \frac{1}{2} \times 60^\circ = 30^\circ$$

$$\angle APB = \angle BAP = 30^\circ \Rightarrow AB = PB$$

Similarly AC = CQ

$$\therefore AB + BC + CA = PB + BC + CQ = 15 \text{ cm}$$

$$\text{Also } \angle ABC = \angle RPB = 60^\circ \text{ and } \angle ACB = \angle SQS = 45^\circ$$

**Q.3. A tent is made in the form of a frustrum A of a right circular cone surmounted by another right circular cone B. The diameter of the ends of the frustrum A are 8 m and 4 m, its height is 3 m and the height of the cone B is 2 m. Find the area of the canvas required. (1979)**

**Ans. Sol.** Slant height of frustrum  $A = \sqrt{(4-2)^2 + 3^2} = \sqrt{13}$

$$\therefore \text{Curved surface area of frustrum} = \pi(4+2)\sqrt{13}$$

$$= 6\sqrt{13}\pi \text{ m}^2$$

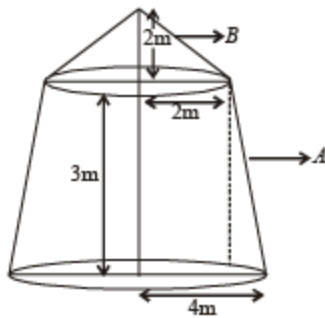

Also slant height of cone  $B = \sqrt{2^2 + 2^2} = 2\sqrt{2}$

$$\therefore \text{Curved surface area of cone} = \pi \times 2 \times 2\sqrt{2} = 4\sqrt{2}\pi \text{ m}^2$$

$$\therefore \text{Area of canvas required} = 6\sqrt{13}\pi + 4\sqrt{2}\pi$$

$$= 2(3\sqrt{13} + 2\sqrt{2})\pi \text{ m}^2.$$

**Q.4. In calculating the mean and variance of 10 readings, a student wrongly used the figure 52 for the correct figure of 25. He obtained the mean and variance as 45.0 and 16.0 respectively. Determine the correct mean and variance. (1979)**

**Ans. Sol.** Let the remaining 9 readings be  $x_1, x_2, x_3, \dots, x_9$  and tenth is taken by the student as 52.

$$\therefore \text{Incorrect mean} = \frac{x_1 + x_2 + \dots + x_9 + 52}{10} = 45$$

$$\Rightarrow x_1 + x_2 + \dots + x_9 = 450 - 52 = 398$$

$$\therefore \text{Correct mean} = \frac{x_1 + x_2 + \dots + x_9 + 25}{10} = \frac{398 + 25}{10}$$

$$\Rightarrow \text{Correct mean} = 42.3$$

$$\text{Incorrect variance} = \frac{\sum(x_i - \bar{x})^2}{n}$$

$$\Rightarrow 16 = \frac{(x_1 - 45)^2 + (x_2 - 45)^2 + \dots + (x_9 - 45)^2 + (52 - 45)^2}{10}$$

$$\Rightarrow (x_1 - 45)^2 + (x_2 - 45)^2 + \dots + (x_9 - 45)^2 = 160 - 49 = 111$$

$$\Rightarrow (x_1^2 + x_2^2 + \dots + x_9^2) - 90(x_1 + x_2 + \dots + x_9) + 9 \times (45)^2 = 111$$

$$\Rightarrow x_1^2 + x_2^2 + \dots + x_9^2$$

$$= 111 + 90 \times 398 - 9 \times (45)^2 = 17706 \dots (2)$$

$$\text{Correct variance} = \frac{\sum(x_i - 42.3)^2}{10}$$

$$= \frac{(x_1 - 42.3)^2 + (x_2 - 42.3)^2 + \dots + (x_9 - 42.3)^2 + (25 - 42.3)^2}{10}$$

$$(x_1^2 + x_2^2 + \dots + x_9^2) - 84.6(x_1 + x_2 + \dots + x_9)$$

$$= \frac{+9 \times (42.3)^2 + 299.29}{10}$$

$$= \frac{17706 - 84.6 \times 398 + 16103.61 + 299.29}{10}$$

$$= \frac{34108.9 - 33670.8}{10} = \frac{438.1}{10} = 43.81$$

**Q.5. The diameter PQ of a semicircle is 6 cm. Construct a square ABCD with points A, B on the circumference, and the side CD on the diameter PQ. Describe briefly the method of construction. (1980)**

**Ans. Sol.** The rough figure is as shown, let  $2x$  be the side of square.

In  $\triangle OBC$   $r^2 = x^2 + 4x^2$

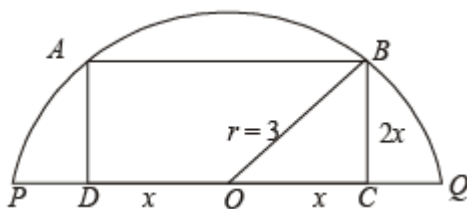

$$\Rightarrow x^2 = \frac{r^2}{5} \Rightarrow x = \frac{r}{\sqrt{5}} = \frac{3}{\sqrt{5}} = \frac{3\sqrt{5}}{5}$$

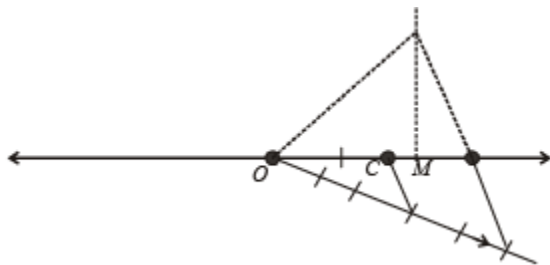

Now on number line we locate M such that  $OM = \sqrt{5}$

Divide OM in five equal parts and take a point C on it such that  $OC : CM = 3 : 2$ . So,

that  $OC = \frac{3}{5}\sqrt{5}$

Now, draw a line segment  $PQ = 6$  cm whose mid-point is O.

From this cut a line segment  $OC = \frac{3\sqrt{5}}{5}$  and  $OD = \frac{3\sqrt{5}}{5}$  on opposite sides of O.

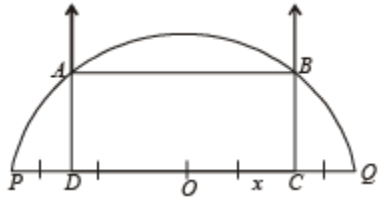

At C and B draw perpendiculars to PQ. With O as centre and OP as radius, draw a semicircle intersecting the perpendiculars drawn at C & D at A and P respectively. Join AB. ABCD is the required square.

**Q.6. C and D are any two points on the same side of a line L. Show how to find a point P on the line L such that PC and PD are equally inclined to the line L. Justify your steps. (1980)**

**Ans. Sol.** Here we are given two points C and D on the same side of line L. To find a point P on L such that PC and PD are equally inclined to L.

**Steps of Construction:** 1. From C draw  $CE \perp L$  and produce it to  $C'$  such that  $EC' = EC$ .

2. Join  $C'D$  intersecting L at P. Also join CP.

3. By simple geometry  $\angle 1 = \angle 2$  and  $\angle 2 = \angle 3 \Rightarrow \angle 1 = \angle 3$

$\therefore$  PC and PD are the required lines inclined equally to L.

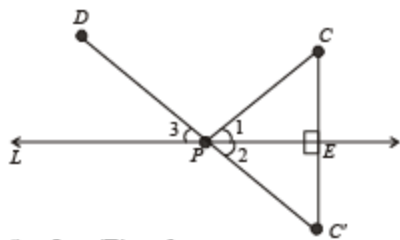

**Q.7. (i) Set A has 3 elements, and set B has 6 elements. What can be the minimum number of elements in the set  $A \cup B$ ? (1980) (ii) P, Q, R are subsets of a set A. Is the following equality true?**

$R \times (P^c \cup Q^c)^c = (R \times P) \cap (R \times Q)$ ? (1980)



(iii) For any two subset X and Y of a set A define  $X \circ Y = (X^c \cap Y) \cup (X \cap Y^c)$  Then for any three subsets X, Y and Z of the set A, is the following equality true.  $(X \circ Y) \circ Z = X \circ (Y \circ Z)$ ? (1980)

**Ans. Sol.** (i)  $n(A) = 3, n(B) = 6$

We know that  $n(A \cup B) \geq \max(n(A), n(B)) \Rightarrow n(A \cup B) \geq 6$

$\therefore$  Min number of element that  $A \cup B$  can have is 6.

(ii) Here  $R \times (P^c \cup Q^c)^c = R \times (P \cap Q) = (R \times P) \cap (R \times Q)$

$\therefore$  Given equality is true.

(iii) Yes

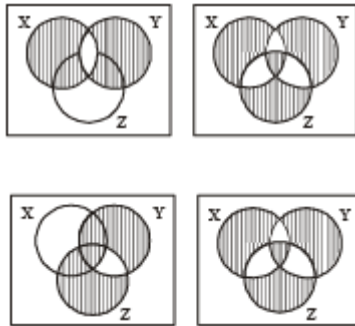

From (1) and (2)  $(X \circ Y) \circ Z = X \circ (Y \circ Z)$

**Q.8. Suppose  $A_1, A_2, \dots, A_{30}$  are thirty sets each with five elements and  $B_1, B_2,$**

**$\dots, B_n$  are  $n$  sets each with three elements. Let  $\bigcup_{i=1}^{30} A_i = \bigcup_{j=1}^n B_j = S$ . Assume that each element of  $S$  belongs to exactly ten of the  $A_i$ 's and to exactly nine of the  $B_j$ 's. Find  $n$ . (1981 - 2 Marks)**

**Ans. Sol.** We are given that  $\bigcup_{i=1}^{30} A_i = \bigcup_{j=1}^n B_j = S \dots(1)$

Each  $A_i$ 's contain 5 elements, so  $\bigcup_{i=1}^{30} A_i$  contains  $5 \times 30 = 150$  elements (with repetition) out of which each element is repeated 10 times, (as given that each element of  $S$  belongs to 10  $A_i$ 's)

$\therefore$  Number of different elements in  $\bigcup_{i=1}^{30} A_i$  is  $= \frac{150}{10} = 15$

$\therefore$  From eqn. (1) we can say S contains 15 elements...(2) Again each  $B_j^s$  contains 3

elements, so  $\bigcup_{j=1}^n B_j$  contains  $3 \times n = 3n$  elements (with repetition), out of which each element is repeated 9 times (as each element of S belongs to 9  $B_j^s$ )

$\therefore$  No. of different elements in  $\bigcup_{j=1}^n B_j = \frac{3n}{9} = \frac{n}{3}$

$\therefore$  From eqn. (1) we can say S contain  $n/3$  elements....(3) From (2) and (3) we get  $\frac{n}{3} = 15 \Rightarrow n = 45$

**Q.9. The mean square deviations of a set of observations  $x_1, x_2, \dots, x_n$  about a point  $c$  is defined to be**

$\frac{1}{n} \sum_{i=1}^n (x_i - c)^2$  **The mean square deviations about  $-1$  and  $+1$  of a set of observations are**

**7 and 3 respectively. Find the standard deviation of this set of observations. (1981 - 2 Marks)**

**Ans. Sol. Given that:** Mean square deviation for the observations  $x_1, x_2, \dots, x_n$ , about a point.  $c$  is given by  $\frac{1}{n} \sum_{i=1}^n (x_i - c)^2$  Also given that mean square deviations about  $-1$  and  $+1$  are 7 and 3 for a particular set of observations.

$$\Rightarrow \frac{1}{n} \sum_{i=1}^n (x_i + 1)^2 = 7 \quad \text{And} \quad \frac{1}{n} \sum_{i=1}^n (x_i - 1)^2 = 3$$

$$\Rightarrow \sum_{i=1}^n (x_i^2 + 2x_i + 1) = 7n \quad \text{And} \quad \sum_{i=1}^n (x_i^2 - 2x_i + 1) = 3n$$

$$\Rightarrow \sum x_i^2 + 2\sum x_i + n = 7n \quad \text{And NOTE THIS STEP}$$

$$\sum x_i^2 - 2\sum x_i + n = 3n$$

$$\Rightarrow \sum x_i^2 + 2\sum x_i = 6n \dots(1)$$

$$\text{And } \sum x_i^2 - 2\sum x_i = 2n \dots(2)$$

Subtracting (2) from (1), we get

$$4\sum x_i = 4n \Rightarrow \frac{\sum x_i}{n} = 1 \Rightarrow \bar{x} = 1$$

Now standard deviation for same set of observations

$$= \sqrt{\frac{1}{n} \sum_{i=1}^n (x_i - \bar{x})^2} = \sqrt{\frac{1}{n} \sum_{i=1}^n (x_i - 1)^2} = \sqrt{3}$$

{Using the given value}

**Q.10. The marks obtained by 40 students are grouped in a frequency table in class intervals of 10 marks each. The mean and the variance obtained from this distribution are found to be 40 and 49 respectively. It was later discovered that two observations belonging to the class interval (21–30) were included in the class interval (31–40) by mistake. Find the mean and the variance after correcting the error. (1982 - 3 Marks)**

**Ans. Sol.**  $n = 40$   $\bar{x} = 40$ ,  $\text{Var.} = 49$

$$\frac{\sum f_i x_i}{40} = \bar{x} = 40 \Rightarrow \sum f_i x_i = 1600 \dots(1)$$

$$\text{Also Var.} = 49 = \frac{1}{40} \sum f_i (x_i - 40)^2$$

$$\Rightarrow 49 = \frac{1}{40} \sum f_i x_i^2 - 2 \sum f_i x_i + 40 \sum f_i$$

$$\Rightarrow 49 = \frac{1}{40} \sum f_i x_i^2 - 2 \times 1600 + 40 \times 40$$

$$\Rightarrow \frac{1}{40} \sum f_i x_i^2 = 1649 \dots(2)$$

Let  $21 - 30$  and  $31 - 40$  denote the  $k^{\text{th}}$  and  $(k + 1)^{\text{th}}$  class intervals respectively. Then if before correction  $f_k$  and  $f_{k+1}$  are the frequencies of these intervals then after correction (2 observations are shifted from  $31 - 40$  to  $21 - 30$ ), frequency of  $k^{\text{th}}$  intervals becomes  $f_k + 2$  and frequency of  $(k + 1)^{\text{th}}$  interval becomes  $f_{k+1} - 2$ . Then, we get

$$\begin{aligned} \bar{x}_{new} &= \frac{1}{40} \sum_{i=1}^{40} f_i x_i + \frac{2}{40} (x_k - x_{k+1}) \\ &= \frac{1}{40} \sum_{i=1}^{40} f_i x_i + \frac{1}{20} (-10) \\ &= 40 - 0.5 = 39.5 \\ \text{Var}_{new} &= \frac{1}{40} \left[ \sum_{i=1, i \neq k, k+1}^{40} f_i (x_i - 39.5)^2 + f_k (x_k - 39.5)^2 \right. \\ &\quad \left. + f_{k+1} (x_{k+1} - 39.5)^2 \right] \\ &= \frac{1}{40} \left[ \sum_{i=1, i \neq k, k+1}^{40} (f_i x_i^2 - 79 f_i x_i + 39.5)^2 f_i \right] \\ &+ \frac{1}{40} \left[ f_k x_k^2 - 79 f_k x_k + (39.5)^2 f_k + f_{k+1} x_{k+1}^2 \right. \\ &\quad \left. - 79 f_{k+1} x_{k+1} + (39.5)^2 f_{k+1} \right] \\ &= \frac{1}{40} \sum_{i=1}^{40} f_i x_i^2 - 79 \cdot \frac{1}{40} \sum_{i=1}^{40} f_i x_i + (39.5)^2 \frac{1}{40} \sum_{i=1}^{40} f_i \\ &= 1649 - 3160 + 1560.25 = 49.25 \quad [\text{Using eqn. (1) and (2)}] \end{aligned}$$

**Q.11. A relation R on the set of complex numbers is defined by  $z_1 R z_2$  if and only if**

$$\frac{z_1 - z_2}{z_1 + z_2} \text{ is real. Show that R is an equivalence relation. (1982 - 2 Marks)}$$

**Ans. Sol.** Given that  $z_1 R z_2$  iff  $\frac{z_1 - z_2}{z_1 + z_2}$  is real.

To show that R is an equivalence relation.

Reflexivity : For  $z_1 = z_2 = z$  (say)

$$\frac{z_1 - z_2}{z_1 + z_2} = \frac{z - z}{z + z} = 0 \text{ which is real}$$

$\therefore z R z \forall z \quad \therefore R$  is reflexive.

Symmetric: Let  $z_1 R z_2 \Rightarrow \frac{z_1 - z_2}{z_1 + z_2}$  is real  $\Rightarrow -\left(\frac{z_1 - z_2}{z_1 + z_2}\right)$  is also real

$$\Rightarrow \frac{z_2 - z_1}{z_2 + z_1} \text{ is real} \Rightarrow z_2 R z_1 \Rightarrow R \text{ is symmetric.}$$

Transitivity : Let  $z_1 R z_2$  and  $z_2 R z_3$

$$\Rightarrow \frac{z_1 - z_2}{z_1 + z_2} \text{ is real and } \frac{z_2 - z_3}{z_2 + z_3} \text{ is also real}$$

$$\text{Now, } \frac{z_1 - z_2}{z_1 + z_2} \text{ is real} \Rightarrow I_m \left( \frac{z_1 - z_2}{z_1 + z_2} \right) = 0$$

$$\Rightarrow I_m \left( \frac{(x_1 - x_2) + i(y_1 - y_2)}{(x_1 + x_2) + i(y_1 + y_2)} \right) = 0$$

$$\begin{aligned} \Rightarrow I_m ((x_1 - x_2) + i(y_1 - y_2))((x_1 + x_2) - i(y_1 + y_2)) &= 0 \\ \Rightarrow (x_1 + x_2)(y_1 - y_2) - (x_1 - x_2)(y_1 + y_2) &= 0 \\ \Rightarrow x_2 y_1 - x_1 y_2 &= 0 \end{aligned}$$

$$\Rightarrow \frac{x_1}{y_1} = \frac{x_2}{y_2} \dots (1)$$

$$\text{Similarly, } I_m \left( \frac{z_2 - z_3}{z_2 + z_3} \right) = 0 \Rightarrow \frac{x_2}{y_2} = \frac{x_3}{y_3} \dots (2)$$

$$\text{From (1) and (2) we get } \frac{x_1}{y_1} = \frac{x_3}{y_3}$$

$$\Rightarrow \operatorname{Im}\left(\frac{z_1 - z_3}{z_1 + z_3}\right) = 0 \Rightarrow \frac{z_1 - z_3}{z_1 + z_3} \text{ is real}$$

$\Rightarrow z_1 R z_3 \therefore R$  is transitive.

Thus  $R$  is reflexive, symmetric and transitive.

Hence  $R$  is an equivalence relation.

## Match the following of Miscellaneous (Sets, Relations, Statistics & Mathematical Reasoning)

Each question contains statements given in two columns, which have to be matched. The statements in Column-I are labelled A, B, C and D, while the statements in Column-II are labelled p, q, r, s and t. Any given statement in Column-I can have correct matching with ONE OR MORE statement(s) in Column-II. The appropriate bubbles corresponding to the answers to these questions have to be darkened as illustrated in the following example :

	p	q	r	s	t
A	<input checked="" type="radio"/>	<input type="radio"/>	<input type="radio"/>	<input checked="" type="radio"/>	<input checked="" type="radio"/>
B	<input type="radio"/>	<input checked="" type="radio"/>	<input checked="" type="radio"/>	<input type="radio"/>	<input type="radio"/>
C	<input checked="" type="radio"/>	<input checked="" type="radio"/>	<input type="radio"/>	<input type="radio"/>	<input type="radio"/>
D	<input type="radio"/>	<input type="radio"/>	<input type="radio"/>	<input checked="" type="radio"/>	<input type="radio"/>

If the correct matches are A-p, s and t; B-q and r; C-p and q; and D-s then the correct darkening of bubbles will look like the given.

**Q. Match the statements given in Column-I with the intervals/union of intervals given in Column-II. (2011)**

**Column-I**

**Column-II**

(A) The set  $\left\{ \operatorname{Re} \left( \frac{2iz}{1-z^2} \right) : z \text{ is a complex number, } |z| = 1, z \neq \pm 1 \right\}$  is  $(-\infty, -1) \cup (1, \infty)$

(p) (-

(B) The domain of the function  $f(x) = \sin^{-1} \left( \frac{8(3)^{x-2}}{1-3^{2(x-1)}} \right)$  is  $(-\infty, -0) \cup (0, \infty)$

(q) (-

(C) If  $f(\theta) = \begin{vmatrix} 1 & \tan \theta & 1 \\ -\tan \theta & 1 & \tan \theta \\ -1 & -\tan \theta & 1 \end{vmatrix}$ , then the set  $\left\{ f(\theta) : 0 \leq \theta < \frac{\pi}{2} \right\}$  is

(r)  $[2, \infty)$   
(s

)  $(-\infty, -1] \cup [1, \infty)$

(D) If  $f(x) = x^{3/2}(3x - 10)$ ,  $x \geq 0$  then  $f(x)$  is increasing in (t)  $(-\infty, 0] \cup [2, \infty)$

Ans. Sol. A  $\rightarrow$  (s), B  $\rightarrow$  (t), C  $\rightarrow$  (r) D  $\rightarrow$  (r)

Let  $z = x + iy$  where  $x^2 + y^2 = 1$  and  $x \neq \pm 1$

$$\text{Then } \operatorname{Re} \left( \frac{2iz}{1-z^2} \right) = \operatorname{Re} \left( \frac{2i(x+iy)}{1-(x^2-y^2+2ixy)} \right)$$

$$= \operatorname{Re} \left( \frac{-2y+2ix}{1-x^2+y^2-2ixy} \right) = \operatorname{Re} \left( \frac{-2y+2ix}{2y(y-ix)} \right)$$

$$= \operatorname{Re} \left( \frac{-1}{y} \right) = \frac{-1}{y}$$

Where  $-1 \leq y \leq 1 \Rightarrow \frac{-1}{y} \geq 1$  or  $\frac{-1}{y} \leq -1$

$$\therefore \operatorname{Re} \left( \frac{2iz}{1-z^2} \right) \in (-\infty, -1] \cup [1, \infty) \quad \therefore A \rightarrow s$$

(B) For the domain of  $f(x) = \sin^{-1} \left( \frac{8(3)^{x-2}}{1-3^{2(x-1)}} \right)$

We should have

$$-1 \leq \left( \frac{8(3)^{x-2}}{1-3^{2(x-1)}} \right) \leq 1 \Rightarrow -1 \leq \frac{8 \cdot 3^x}{9-3^{2x}} \leq 1$$

Let  $3^x = t$  then  $-1 \leq \frac{8t}{9-t^2} \leq 1$

$$\Rightarrow \frac{8t}{9-t^2} \geq -1 \text{ and } \frac{8t}{9-t^2} \leq 1$$

$$\Rightarrow \frac{8t+9-t^2}{9-t^2} \geq 0 \text{ and } \frac{8t-9+t^2}{9-t^2} \leq 0$$



$$\Rightarrow \frac{t^2 - 8t - 9}{t^2 - 9} \geq 0 \quad \text{and} \quad \frac{t^2 + 8t - 9}{t^2 - 9} \geq 0$$

$$\Rightarrow \frac{(t-9)(t+1)}{(t-3)(t+3)} \geq 0 \quad \text{and} \quad \frac{(t+9)(t-1)}{(t+3)(t-3)} \geq 0$$

Also  $t = 3x$  can not be -ve

$$\therefore t \in (0, 3) \cup [9, \infty) \quad \text{and} \quad t \in (0, 1] \cup [3, \infty)$$

$$\text{P } x \in (-\infty, 1) \cup [2, \infty) \quad \text{and} \quad x \in (-\infty, 0] \cup (1, \infty)$$

Combining the two, we get  $x \in (-\infty, 0] \cup [2, \infty)$

$$\therefore B \rightarrow t$$

(C)

$$f(\theta) = \begin{vmatrix} 1 & \tan \theta & 1 \\ -\tan \theta & 1 & \tan \theta \\ -1 & -\tan \theta & 1 \end{vmatrix}$$

$$\text{R}_1 + \text{R}_3$$

$$= \begin{vmatrix} 0 & 0 & 2 \\ -\tan \theta & 1 & \tan \theta \\ -1 & -\tan \theta & 1 \end{vmatrix}$$

$$= 2(1 + \tan^2 \theta) = 2\sec^2 \theta \in [2, \infty) \quad \text{for } 0 \leq \theta < \frac{\pi}{2}$$

$$\therefore C \rightarrow r$$

$$(D) f(x) = x^{3/2}(3x - 10), x \geq 0$$

$$\therefore f'(x) = \frac{3}{2}\sqrt{x}(3x - 10) + 3x\sqrt{x}$$

For  $f(x)$  to be increasing  $f'(x) \geq 0$

$$\Rightarrow 3\sqrt{x}[3x - 10 + 2x] \geq 0$$

$$\Rightarrow \sqrt{x}(5x - 10) \geq 0 \quad \text{but } x \geq 0 \Rightarrow x \geq 2$$

$\therefore f(x)$  is increasing on  $[2, \infty)$   $\therefore D \rightarrow r$ .